



**White Paper from VAI Flight Operations
Industry Advisory Council**



VAI Estimating Distance

A Training Reference Guide for Aircrews

September 2021

1.1 About this Publication

Document Name: VAI Estimating Distance: A Training Reference Guide for Aircrews

Edition: First, September 2021

Authorization:

This document is authorized by the Helicopter Association International (VAI) and was commissioned by the VAI Training Working Group, chaired by Terry Palmer: Pilot Landing LLC USA.

Principal Author:

Mike Becker: Becker Helicopter Services, Australia

Contributing Authors:

Scott Boughton: Palisade Aviation, LLC, USA

Mike Coligny: Managing Director, CFS & Associates, USA

Randy Rowles: Helicopter Institute, USA, and VAI Board Liaison for the project

James Orrom: Westpac Surf Lifesaving Helicopters, Australia

Editor:

Bev Austen: International Helicopter Theory, Australia

Illustrations and Graphics

Illustrations and graphics are provided for use by the VAI courtesy of Becker Helicopter Services, Australia, and International Helicopter Theory, Australia.

Cover photo provided by Mischa Gelb AKA Pilot Yellow (YouTube: <https://www.youtube.com/user/mischagelb>).

Language and Style

An international team was involved in the development of this document. As a result, language and writing style may not consistently reflect US language conventions.

Disclaimer

This document and any related material are for general training guidance only. The information contained here was obtained from practical experience and knowledge passed on from experienced aircrews. The documentation is designed to be used in conjunction with a structured training course, and relevant parts of the material should be used in accordance with government regulation and company procedures.

No responsibility is taken for the interpretation and application of the information contained in this document. Managing the safety of the aircraft is the sole responsibility of the pilot-in-command.

Any errors or adjustments or suggested changes to the document can be directed to the VAI director of education at education@rotor.org.

Importantly, it should also be noted that no photo or image in the context of this document is in any way depicting that the aircrew or individual pilots-in-command have put the aircraft in a compromising position. Each image was selected (and often taken out of context from the source file or video) for the purpose of illustrating the associated text.

1.2 Contents

1.1	About this Publication	1
1.2	Contents	3
1.3	List of Abbreviations	6
2.	Introduction	8
3	Speed across the Ground.....	11
4	Distance to an Object.....	14
4.1	Local Knowledge	14
4.2	Runway Length.....	15
4.3	Map to Ground and Ground to Map.....	18
4.3.1	Map to Ground	19
4.3.2	Ground to Map	21
5	Height above the Ground.....	22
5.1	Flat Light	23
5.2	Low Contrast.....	24
5.3	Referencing a Topographical Map to Your Position	26
5.4	Referencing Aviation Publications	28
5.5	Using the GPS Terrain Features	29
5.6	Using the Radar Altimeter	29
5.7	Developing Pilot Experience	30
6	Visibility	31
6.1	Get a Weather Forecast and Weather Report Prior to the Flight.....	32
6.2	Look out the Window and Have a Look	33
6.3	Use the Runway to Estimate Visibility	38
6.4	Distance Traveled versus Distance to Go	39
6.5	Listen to AWIS or ATIS of a Local Airport	39
6.6	Ask Other Pilots Who May Have Just Returned from a Flight.....	39
6.7	Summary	40
7	Cloud Base and Distance	41
7.1	Observation Prior to the Flight	42
7.2	Calculation	42
7.3	In-Flight Visual Checks.....	44
7.4	Asking Another Pilot.....	44
7.5	Distance from the Cloud.....	45
8	Make a Decision	47

List of Figures

Figure 1 Airspace diagram.....	9
Figure 2 Old woman or young woman?	9
Figure 3 Duck or rabbit?	9
Figure 4 Eight beams or seven?	10
Figure 5 Straight and level, or a right turn?	10
Figure 6 Flight computer (wiz wheel)	11
Figure 7 GPS displaying ground speed (GS).....	11
Figure 8 Time to reach an obstacle	12
Figure 9 Height / Velocity Chart (Bell 206 BIII).....	13
Figure 10 Power curve	13
Figure 11 Viewing known features.....	14
Figure 12 Google Earth view of known features	14
Figure 13 Hervey Bay Aerodrome chart: Runway distance 2000 m	15
Figure 14 Hervey Bay Aerodrome: Google Earth view.....	16
Figure 15 Hervey Bay Aerodrome: Photo view	16
Figure 16 Hervey Bay Aerodrome: Runway divisions	17
Figure 17 Example using runway lengths to estimate distance.....	18
Figure 18 Garmin GPS screen	18
Figure 19 Electronic flight bag	19
Figure 20 Clock codes.....	19
Figure 23 Calculating height AGL.....	22
Figure 24 Example of inadvertent IIMC.....	23
Figure 25 Example of flat light (NTSB image).....	24
Figure 26 Example of flight light (showing horizon) (NTSB image)	24
Figure 27 Example of high-contrast conditions	25
Figure 28 Example of low-contrast conditions.....	25
Figure 29 Example of night flight	26
Figure 32 Kingaroy Aerodrome chart highlighting elevation.....	28
Figure 33 GPS terrain page.....	29
Figure 34 EFB terrain option.....	29
Figure 35 Analog radar altimeter	29

Figure 36 Digital radar altimeter	29
Figure 37 Flying at 500 ft AGL.....	30
Figure 38 Visibility by day.....	31
Figure 39 Visibility at night.....	31
Figure 42 Viewing known features.....	33
Figure 43 Google Earth view of known features	33
Figure 44 Estimated visibility at 10km+ or 6+ SM with cloud base at 900 ft.....	34
Figure 45 Estimated visibility at 5000 m or 3 SM with cloud base at 1000 ft.....	34
Figure 46 Estimated visibility at 5000 m or 3 SM with cloud base at 750 ft.....	35
Figure 47 Estimated visibility at 3000 m or 2 SM with cloud base at 500 ft.....	35
Figure 48 Estimated visibility at 3000 m or 2 SM with cloud base at 750 ft.....	36
Figure 49 Estimated visibility at 800 m or 1/2 SM with cloud base at 400 ft.....	36
Figure 52 Foggy runway (Source: Timo.Kouwenhoven at www.skybrary.aero)	38
Figure 53 Distance traveled versus distance to go: 20 NM	39
Figure 54 Distance traveled versus distance to go: 18 NM	39
Figure 55 Observation of clouds prior to flight.....	42
Figure 56 Dew point example	43
Figure 57 Calculating distance to cloud	45

1.3 List of Abbreviations

Abbreviation	Description
AGL	Above Ground Level
AMSL	Above Mean Sea Level
ARFOR	Area Forecast
ATC	Air Traffic Control
ATIS	Automatic Terminal Information Service
AWIS	Agricultural Weather Information Service
CAVOK	Cloud and Visibility OK
CFIT	Controlled Flight into Terrain
DAPs	Departure and Approach Procedures (or Plates)
DP	Dew Point
EDT	Enroute Decision Trigger
EFB	Electronic Flight Bag
FAC	Final Approach Course
ft	Feet
IFR	Instrument Flight Rules
IIMC	Inadvertent Instrument Meteorological Conditions
IMC	Instrument Meteorological Conditions
km	Kilometer
kt	Knots
m	Meter
METAR	Meteorological Aerodrome Report
MFD	Multifunction display
mph	Miles per hour

Abbreviation	Description
NM	Nautical Mile
NVFR	Night Visual Flight Rules
NVIS	Night Vision Imaging System
OAT	Outside Air Temperature
SM	Statute Mile
TAF	Terminal Airdrome Forecast
VFR	Visual Flight Rules
VMC	Visual Meteorological Conditions
VNC	Visual Navigation Chart
VTC	Visual Terminal Chart

2. Introduction

The purpose of this document is to give you, the reader—whether you are a pilot, aircrew member, observer, or passenger—the tools required to make a judgment about distance and closure rate in order to “**see and avoid.**”

When operating a helicopter, it is one thing to have a recommended prescriptive limitation from the regulator or even a recommendation by an association, such as VAI, with regard to a minimum distance from clouds and visibility. It is another to have a pilot make a subjective judgment on what they see and apply that in an operational environment while in flight to achieve the stated prescriptive minimum.

To have some commonality in setting and maintaining a standard, the pilot needs to have some tools, usually gained by experience over time, to be able to determine what is a prescribed distance.

The question, then, is how do you gain this experience to be able to look outside and make an instantaneous judgment in order to avoid a potential conflict?

Unfortunately, the answer is not simple, but in this reference material, we can offer some tools experienced pilots have used over the years. You can apply these in practice and can continually practice them, building on your experience.

From a regulator’s perspective, the prescriptive minimums are in place because some smart person has done the math and determined that, on average, an aircraft travelling at a particular speed needs distance and time for the observer to see and avoid an obstacle (including clouds). Most calculations are based on fixed-wing aircraft, but because the helicopter can go lower and slower without stalling, we can reduce the minimums. That does not necessarily make it the smart thing to do.

The airspace system is designed around the requirements of the airlines, where large passenger-carrying aircraft depart from controlled airspace and climb to a high altitude before descending again, still in controlled airspace, to land. For this reason, the larger and faster and **less** maneuverable the aircraft, the greater the prescriptive minimums for visibility and distance from clouds for all aircraft have to be for them to have time to see and avoid each other.

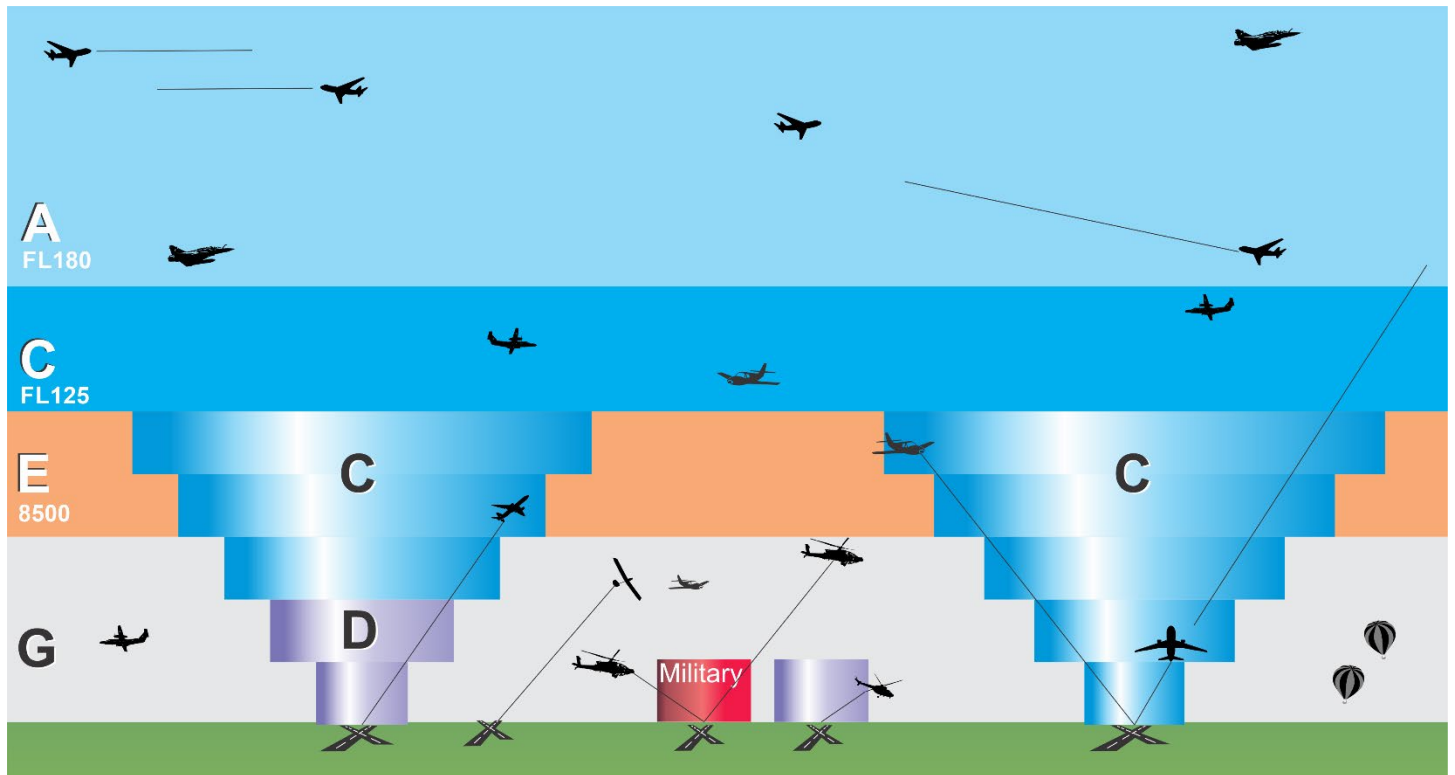

Figure 1 Airspace diagram

No one can see exactly what you are seeing, even when in close proximity, as there are simply too many variables, such as cloud type and density, direction of travel, ambient light, altitude, aircraft speed and type, wind, doors on or off, type of operation, number of crew on board, and so on.

We also need to consider differences in physiology and perception of reality. What one person sees is not necessarily what someone else sees; however, what you think you see becomes your reality. The diagrams below illustrate this issue.

For example, what do you see?



Figure 2 Old woman or young woman?

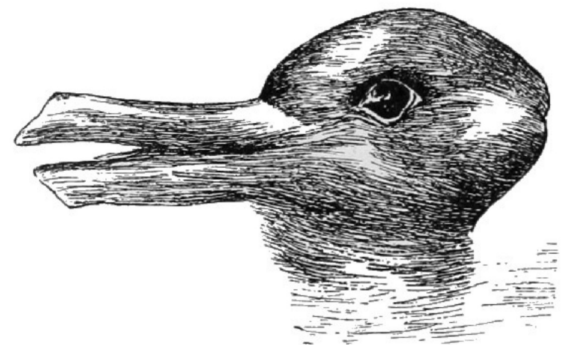

Figure 3 Duck or rabbit?

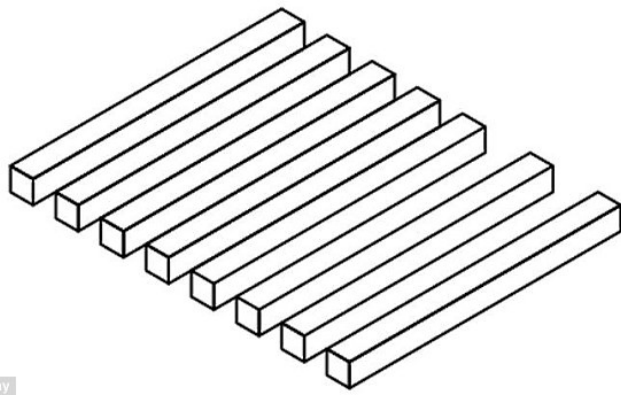

Figure 4 Eight beams or seven?

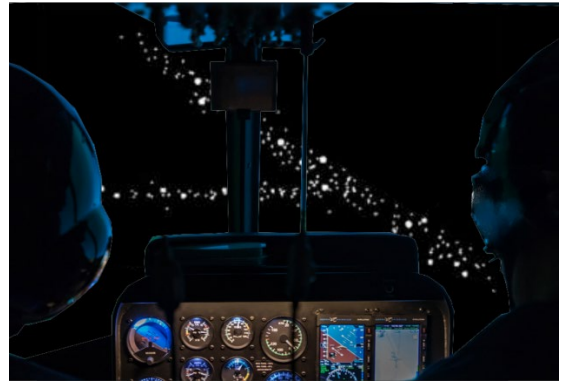

Figure 5 Straight and level, or a right turn?

In essence, you are looking at the exact same images; however, what you see is influenced by the way your brain is wired, your past experiences, and your bias, and what you see is what you believe until being shown another reality.

This means one **technique** cannot and should not fit all, even when operating to a common rule set.

The basic VFR attitude is described as “**see and avoid**,” and the prescriptive minimums are, for all intents and purposes, at best a **guide to aim for** rather than a strict limitation that is legally binding. Although this may on the surface appear to be a poor attitude to have towards regulations, it is in all practicality the only way to apply them without installing exacting measuring instruments in the aircraft displaying the visibility and distance from obstacles in real time.

The overall purpose of the minimums is to give pilots and crew the time to be able to see an obstacle and then avoid it, regardless of the fine detail contained within prescriptive minimums. It is, therefore, up to the pilot to make a **judgment** based on the prevailing conditions. For this reason, the VMC minimums have always been “pliable,” based on the observer’s interpretation. This reference material is designed to give you the tools to enable that judgment.

There are several key anchors that VFR pilots need to have ingrained into their psyche (brain + attitude) to assist in decision-making. These anchors include a working knowledge of

- speed across the ground;
- distance to a feature, object, or obstacle (including clouds);
- height AGL;
- visibility (how far can I see?); and
- cloud base.

All these items together will sum up the pilot’s personal skill set, which we often refer to as “experience.” Being able to determine these five things will lead to better decision-making in marginal weather, which is both the first and final step in the process of aviating: **making a decision**.

Decision-making and IIMC (Inadvertent flight into Instrument Meteorological Conditions) will be the main subject of a separate training reference document that follows on from this material titled [VAI Decision-Making and IIMC: A Training Reference Guide for Aircrews](#).

3 Speed across the Ground

Although this may seem simple, knowing your speed across the ground and being able to apply that knowledge to your situation leads to a better understanding of how far away you are from objects, such as clouds.

First, knowing your ground speed is either done:

- 1 the old way, by using a flight computer (also known as a wiz wheel) (Figure 6) and calculating a distance over time to get an average ground speed, or

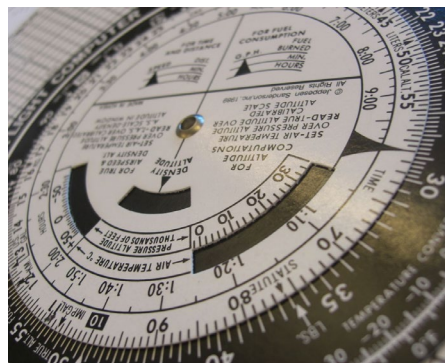

Figure 6 Flight computer (wiz wheel)

- 2 the current way, by simply looking at the GPS (Figure 7) or the electronic flight bag (EFB), running ForeFlight, OzRunways, or another similar app, which displays the ground speed in real time.



Figure 7 GPS displaying ground speed (GS)

For easy reference, the ground speed should be considered with the following standard rates in mind:

Ground speed (kt or mph)	Distance traveled across the ground (NM or SM)		
	1 Minute	30 Seconds	15 Seconds
60	1 Mile (1600 m)	½ Mile (800 m)	¼ Mile (250 m)
90	1.5 SM (2500 m)	¾ Mile (1200 m)	1/3 Mile (400 m)
120	2 SM (3000 m)	1 Mile (1600 m)	½ Mile (800 m)

Note: Conversions to meters are approximate based on the SM scale.



Figure 8 Time to reach an obstacle

NOTE

Different countries use different scales. Some use miles per hour (mph) and talk in statute miles (SM) and feet (ft) while others use knots per hour (kt) and talk in nautical miles (NM) and meters (m). Some countries mix them all up together so that NM, SM, meters, and feet are discussed in the same sentence to describe vertical and horizontal distance differently.

Although 1 NM = 6076 ft and 1 SM = 5280 ft, meaning the distance traveled over time and the distance you are measuring will be different depending on the units, the reality is that the concept of time and distance remains the same and you can simply use the scale you are familiar with rather than trying to do any fancy conversions in your head.

The fact that those using kt and NM may have a slightly bigger distance margin compared with those using mph and SM is negated by the fact that 60 kt is faster (101 ft per second) than 60 mph (88 ft per second).

The point is **not** to be overly hung up on the accuracy, but to gain an understanding of the concept of **closure rate** to the obstacle and the **time** required to make a decision and take corrective action prior to conflicting with the obstacle.

In this document, we will mention both kt and mph, NM and SM, and you can relate the recommendations to the scale you use in your aircraft.

When flying low level and particularly in bad weather, pilots are taught to **slow down**. Each aircraft model has its **own unique set of parameters and speed limitations** that will

- put the helicopter's profile outside of the Height / Velocity Diagram (Deadman's Curve) (Figure 9),
- allow maximum power to be available for the conditions (Figure 10),
- allow the pilot to look ahead and then plan ahead with sufficient time to see and avoid, and
- configure the helicopter in the correct flight profile for the design.

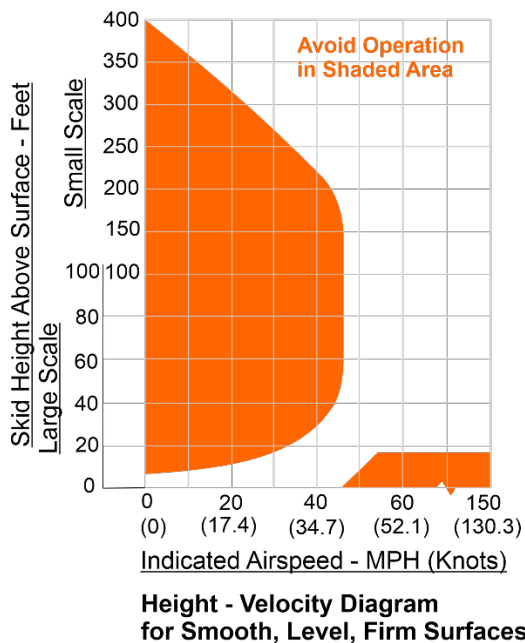

Figure 9 Height / Velocity Chart (Bell 206 BIII)

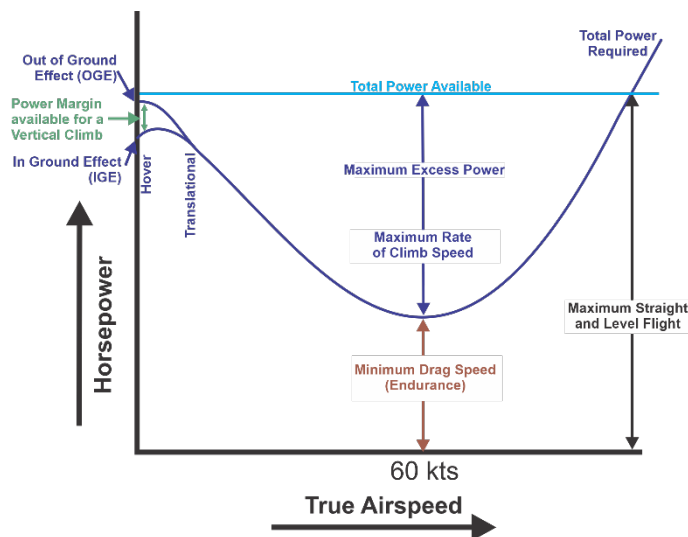

Figure 10 Power curve

Flying even slower may be completely acceptable when you need to **“fly to the conditions”** or due to the **nature of the operation**. However, if the pilot is feeling the need to reduce speed below a set minimum because of reduced visibility, then reducing airspeed should be one of the triggers indicating that the pilot should be enacting the decision for the alternative course of action (turn, descend, land) instead of pushing on.

**At 60 (kt or mph) with ½ SM (800 m) visibility
the pilot has 30 seconds
to see and avoid inclement weather or an obstacle.**

By now, it should start to become obvious why the VMC prescriptive minimums are in place and why ½ SM (800 m) is the minimum required visibility for VFR aircraft.

4 Distance to an Object

Now that we understand closure rate, the next step is to be able to estimate the distance to the obstacle. This is easier to do on the ground as there are multiple reference points to choose from and they are static (not moving), which gives you time to think and cross-reference other helpful information. In the air, the pilot must estimate the distance while moving at speed in a changing environment. Measuring distance, therefore, is a skill that needs to be learned and practiced so that estimation becomes instinctive and automatic. Remember that the brain is a muscle and muscle memory is important to the instinctive flying ability of a helicopter pilot. Teaching the brain to automatically estimate distance is just as important a skill to have as the other aspects of piloting the aircraft.

Below are several simple techniques used to acquire this skill:

- Local knowledge
- Runway length
- Map to ground and ground to map

4.1 Local Knowledge

Knowing your local area can be an invaluable tool in learning how to estimate distances. By selecting known obstacles and features (Figure 11) and then determining their actual distance from the observation point (Figure 12), you can start to build up experience on estimating distance.

Example

When standing at the hangar door looking out toward the horizon before going flying, the pilot knows exactly where they are and can then look at known obstacles in the distance. Using the Google Earth measuring tool or simply using a topographical map and a ruler, the pilot can then accurately measure the distance from the viewing point to the obstacle and see what that particular distance looks like. That information can then be remembered and be the first building block in being able to see and estimate a distance.

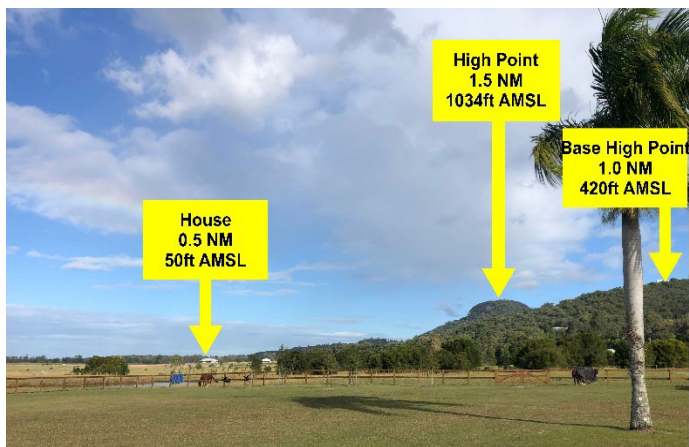

Figure 11 Viewing known features



Figure 12 Google Earth view of known features

4.2 Runway Length

Another common method is to use the length of a known runway as a measuring stick. The runway length is promulgated in documentation and is given in feet or meters. Figure 13 shows an example airdrome chart where the runway is 2000 m (6500 ft) long.

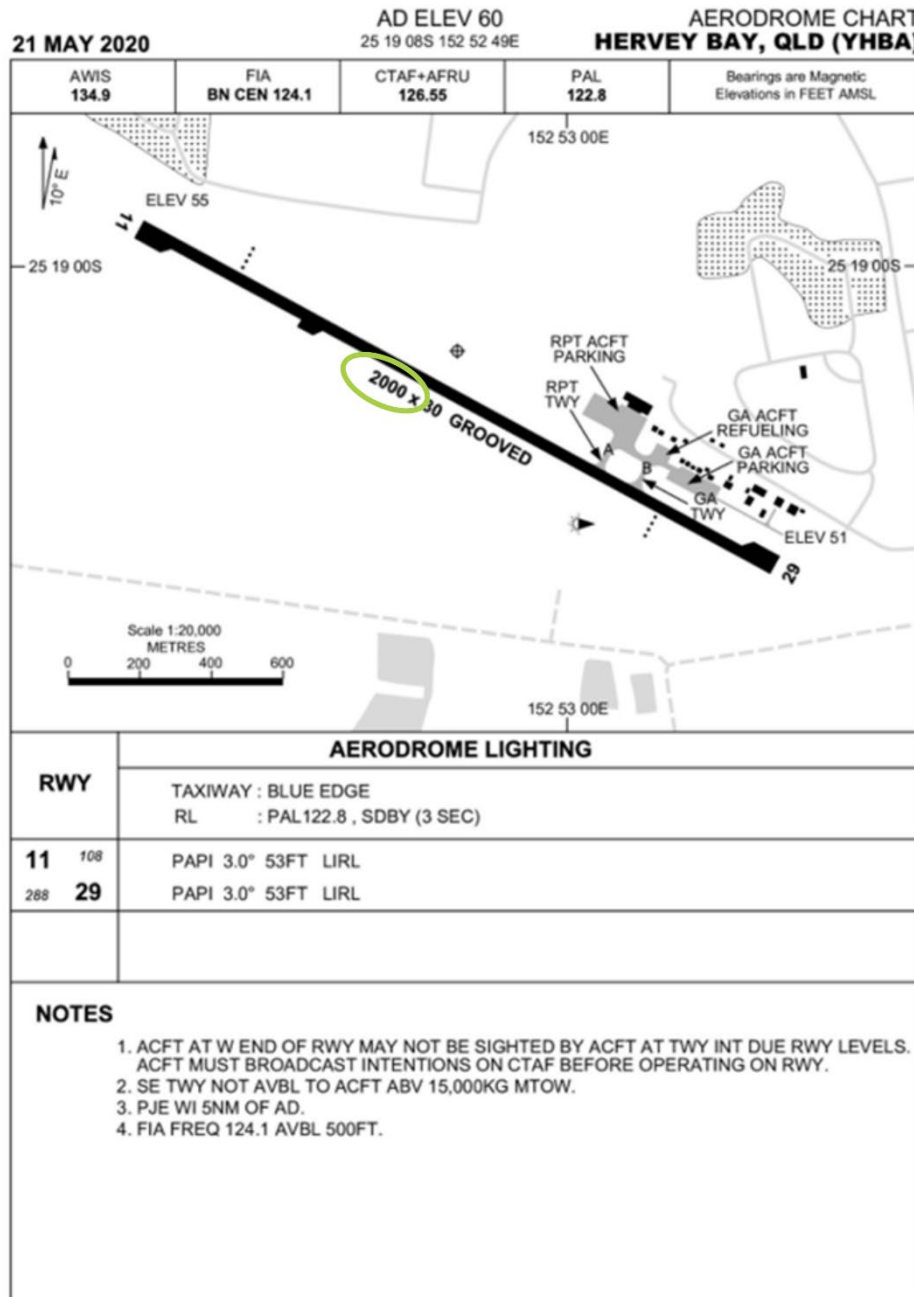

Figure 13 Hervey Bay Aerodrome chart: Runway distance 2000 m

Most regional runways are **approximately** 1 SM long (about 5000 to 6000 ft or 1600 to 1800 m). Again, do not get too hung up on the fine detail, but consider the concept. In Figure 14, the same runway as in the prior chart is shown using Google Earth, measuring the runway with the ruler, and Figure 15 shows a photo view of the same airport. This runway is actually 1.08 NM long, which is the same as 1.2 SM, 6500 ft or 2000 m.

For the purposes of estimation, we can say it is approximately 1 SM long.



Figure 14 Hervey Bay Aerodrome: Google Earth view



Figure 15 Hervey Bay Aerodrome: Photo view

Using the mental image of a runway, the pilot can estimate what half a mile (half the runway) and a quarter mile (a quarter of the runway) look like, as illustrated in Figure 16. With this knowledge, the pilot is then able to project the number of runway lengths to an obstacle, giving a sufficient estimation of distance.



Figure 16 Hervey Bay Aerodrome: Runway divisions

Example

Consider flying at 500 ft AGL and looking at an obstacle out front (Figure 17). You estimate it is approximately 3 and ½ runways, which equates to 3.5 SM.

At a ground speed of 90 kt, you would get there in approximately 2.5 minutes (3.5 SM at 90 kt or 1.5 SM per minute equals 2.3 minutes or 2 minutes 20 seconds).

You have just over 2 minutes to **make a decision** before you conflict with the obstacle!

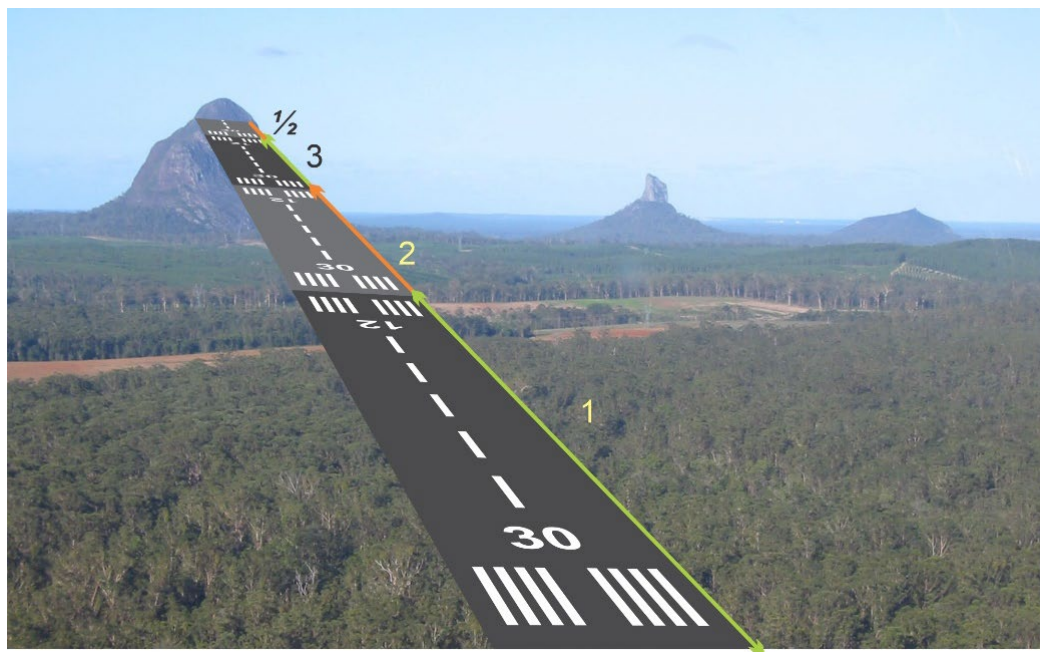

Figure 17 Example using runway lengths to estimate distance

Although helicopters do not typically use the runway environment, we do frequently visit them and use them for training, so it is an opportune time to develop and practice your distance measuring and estimating skills.

4.3 Map to Ground and Ground to Map

When airborne, the pilot should utilize a map for orientation and situational awareness rather than simply rely on the line displayed on the GPS unit (Figure 18).

This map can be either paper based or an electronic moving-map display that is part of an aircraft's MFD (multifunction display) or an EFB (electronic flight bag) utilizing ForeFlight, OzRunways, or similar software (Figure 19).



Figure 18 Garmin GPS screen



Figure 19 Electronic flight bag

Map reading is a dying skill that still has relevance for the VFR pilot and should be practiced on every flight. There are two techniques available for estimating distance when using a map: **map to ground** and **ground to map**.

4.3.1 Map to Ground

When reading map to ground, the pilot will identify the aircraft's current position on the map. They will then look for some obvious features on the map and, projecting out from the aircraft, translate those into a clock code and distance from the aircraft.

The "clock code" refers to superimposing an analog watch face oriented to the aircraft's nose: 12 o'clock is straight ahead, 6 o'clock is directly behind you, and all the other numbers of the clock then relate the clock face to a direction radiating outwards from the helicopter.

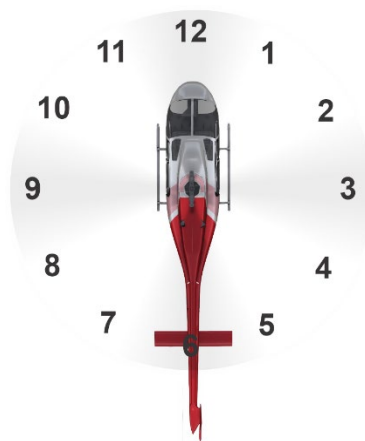

Figure 20 Clock codes

This is a very simple way to orient yourself on a map without having to use compass bearings.

Ever heard the term “check your 6”?



Using the clock code, the pilot then looks outside the cockpit in the determined direction (often with the aid of a pointing hand) and projects the estimated distance (using the distance estimation skills learned earlier) (Figure 21). They then should be able to positively identify the obstacle or feature.

Example



Figure 21 Using map to ground skills to estimate distance and identify features

4.3.2 Ground to Map

When reading ground to map, the pilot will look for some obvious features on the ground and relate that to the clock code and an estimated distance from the aircraft. Looking at the map and knowing the helicopter's current position, the clock code is then superimposed on the map and the pilot projects the estimated distance in the general direction on the map to positively identify the feature (Figure 22).

Example

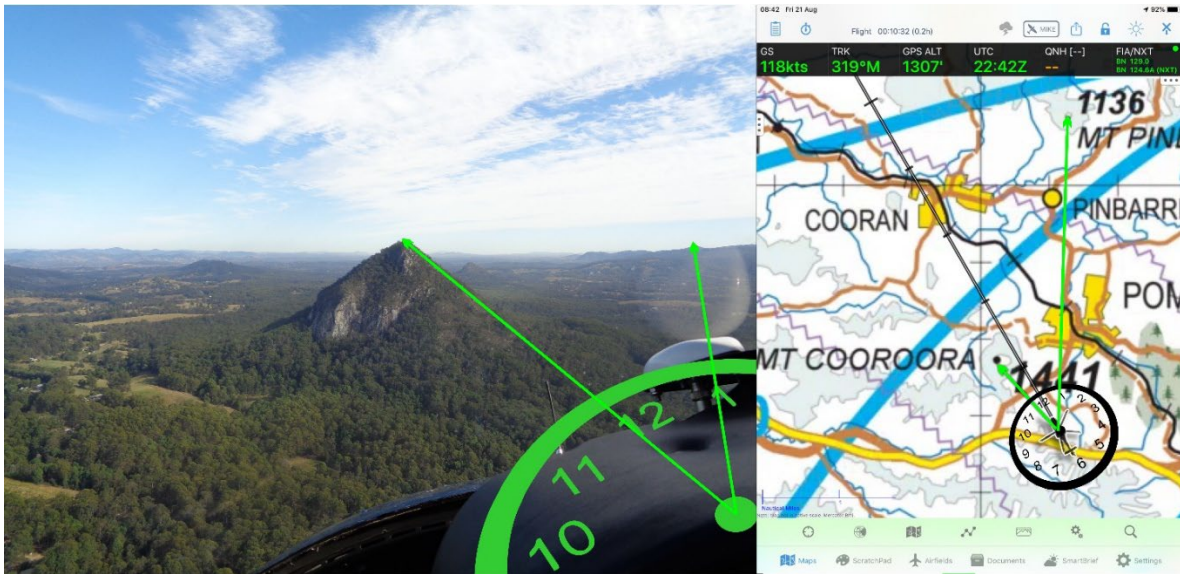

Figure 22 Using ground to map skills to estimate distance and identify features

There are many other methods out there, and, if you ask or are observant, you will find that experienced pilots will pass on their little tricks for determining distance. The key is to choose a method that works for you in making your own determination of distance, thus allowing you to make your own decisions while en route.

If you are shown or learn a new distance technique, go and test it. If it works, then you have a new tool in your arsenal of pilot tricks to use in the future.

5 Height above the Ground

Although height AGL may seem obvious, it is often not seriously considered.

Altitude (AMSL) is easily displayed on the altimeter and is invaluable in helping a pilot determine where the helicopter is positioned in “**the atmosphere,**” but, unless the helicopter has a radar altimeter, it is up to the pilot to determine the height AGL based on the terrain being flown over. This requires interpreting a topographical map to obtain the elevation and then applying that against the altitude displayed on the altimeter. The difference between the two is the height AGL.

For example, consider a helicopter cruising at 3000 ft AMSL and passing over a 2350 ft mountain. The height AGL at the point of passing over the mountain is 650 ft (Figure 23).

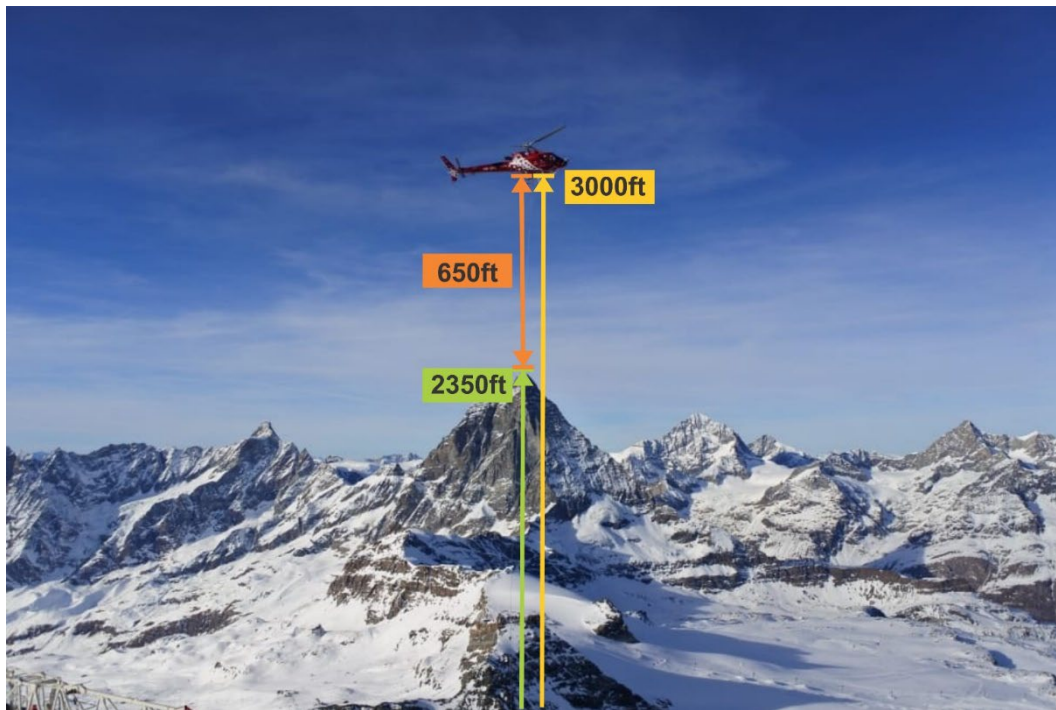

Figure 21 Calculating height AGL

Most countries have very specific visual flight rules (VFR) stating the minimum height allowed to be flown AGL over an unpopulated or populated area. These rules give leeway for aerial work tasks, emergencies, weather, taking off, and landing.

Most aircraft do not get low enough to even consider these minimums in their normal course of aviating from point A to point B, but for helicopters especially, getting close to the ground is normal.

When the weather is fine, the decision to climb over an obstacle is normally an option. When the weather is bad, the climbing option is usually not available, so the pilot attempts to go around the obstacle. With rising terrain and/or a lowering cloud base, the pilot needs to decide early which actions to take. If the pilot is having to descend below a set minimum height AGL because of a lowering cloud base, then the reduced altitude may be another trigger indicating that the pilot should be enacting the decision for the alternative course of action (turn, descend, land) instead of pushing on.

Having height available is an escape route from a lowering cloud base. If the pilot has allowed the helicopter to get so low to the ground that there is no longer an escape route while continuing to fly into reduced visibility (Figure 24), then an inadvertent IMC (IIMC) event often ensues.



Figure 22 Example of inadvertent IIMC

Consideration may also need to be given to flat light conditions and low-contrast environments, as they can lead to visual illusions where, even though the ground can be seen, the pilot no longer has any depth perception. In these cases, the pilot's estimation of height AGL can be way off, which can result in a controlled flight into terrain (CFIT).

5.1 Flat Light

Flat light is a term used to describe when the sky is overcast and the sun is not able to cast any shadows. This masks visual cues and terrain features, making it very difficult for pilots to visually perceive depth, distance, or altitude. This is most relevant when flying over low-contrast environments such as snow, flat still water, or desert.

Figure 25 depicts an accident that occurred because the pilot could not discern between the ground and the sky. Figure 26 has a dotted line that indicates where the actual horizon was that day.



Figure 23 Example of flat light (NTSB image)



Figure 24 Example of flight light (showing horizon) (NTSB image)

5.2 Low Contrast

The term “contrast” describes the differences between how two or more surfaces reflect light.

For example, white or very smooth surfaces will reflect more light compared to dark rough surfaces. If you encounter a surface with varying colors and textures, light can be reflected differently off different parts of it and the contrast between those surface colors and textures will be high (Figure 27). The human eye can then visually see the colors and textures, and the brain will interpret this to give depth perception, enabling judgment of distance and height AGL.



Figure 25 Example of high-contrast conditions

In a low-contrast environment, the surface reflects the light equally (Figure 28). There is no difference in color or texture, so the brain receives limited information to accurately interpret the environment. Instead, it starts filling in the blanks, and the pilot starts to imagine what is being seen. Depth perception and the ability to estimate distance and height AGL will start to disappear.



Figure 26 Example of low-contrast conditions

Flight in a low-contrast environment without the aid of instruments can be very dangerous, and the risk is not limited to daytime VFR flying.

Flat light and low contrast are also problems for the NVFR and NVIS pilot (Figure 29). Away from the urban environment, with either no moon or a high moon (so, again, no shadows are cast), or over terrain with no contrast (flat, smooth water; snow; desert sand), it is difficult for the pilot to distinguish the sky from the ground even if the weather forecast states there is minimal cloud cover and good visibility.



Figure 27 Example of night flight

There are various tools a pilot can use to determine and then maintain a minimum height AGL. These include, but may not be limited to

- referencing a topographical map to your position,
- referencing aviation publications,
- using the GPS and EFB terrain features,
- using the radar altimeter, and
- developing pilot experience.

5.3 Referencing a Topographical Map to Your Position

The colors of a topographical map, called hypsometric tints, correlate with height above sea level (Figure 30). Spot heights within each grid display the highest-known topographical feature or published obstacle, such as a tower (Figure 30).

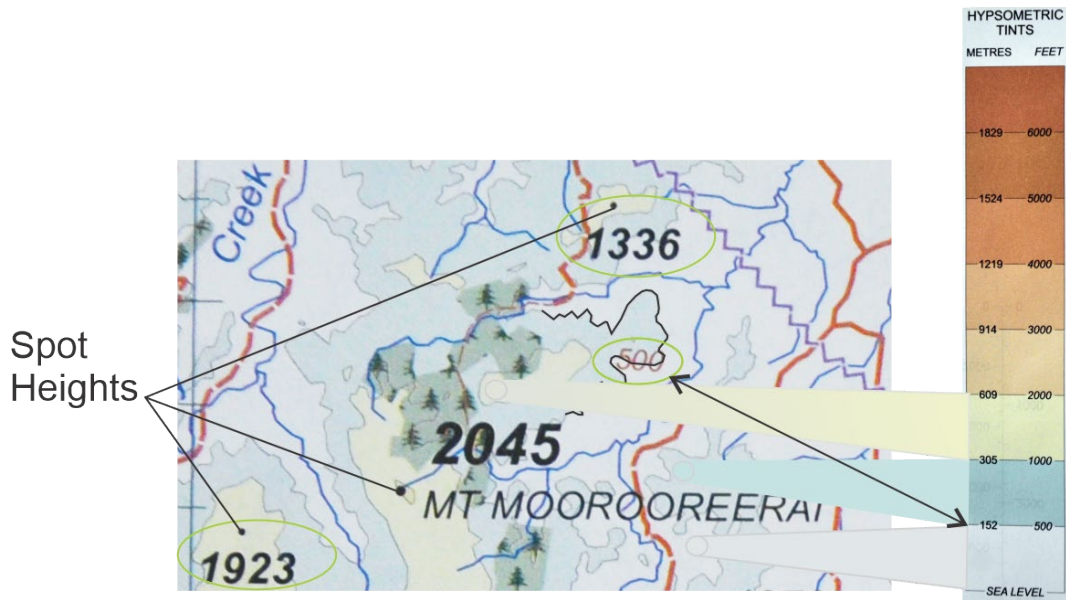

Figure 30 Hypsometric tints on chart

It should be noted that man-made obstacles of less than 360 ft AGL do not necessarily have to be displayed on a map (this height may vary from country to country or state to state). Therefore, if flying in an area about which you have no knowledge, consider that there may be an unmarked obstacle (Figure 31) that is higher than the published terrain.



Figure 31 Man-made obstacles

5.4 Referencing Aviation Publications

Aviation publications, particularly airfield information and aviation maps and charts, including FACs, DAPs, touring guides, sectionals, VTCs, VNCs, etc., all have important information the pilot can study prior to the flight and then continue to use during the flight to help maintain situational awareness of the height above the ground as opposed to the altitude above mean sea level.

For example, consider arriving at an airport where the field elevation is 1492 ft (Figure 32). The standard circuit height as displayed on the altimeter will be 2492 ft, putting the aircraft at 1000 ft AGL.

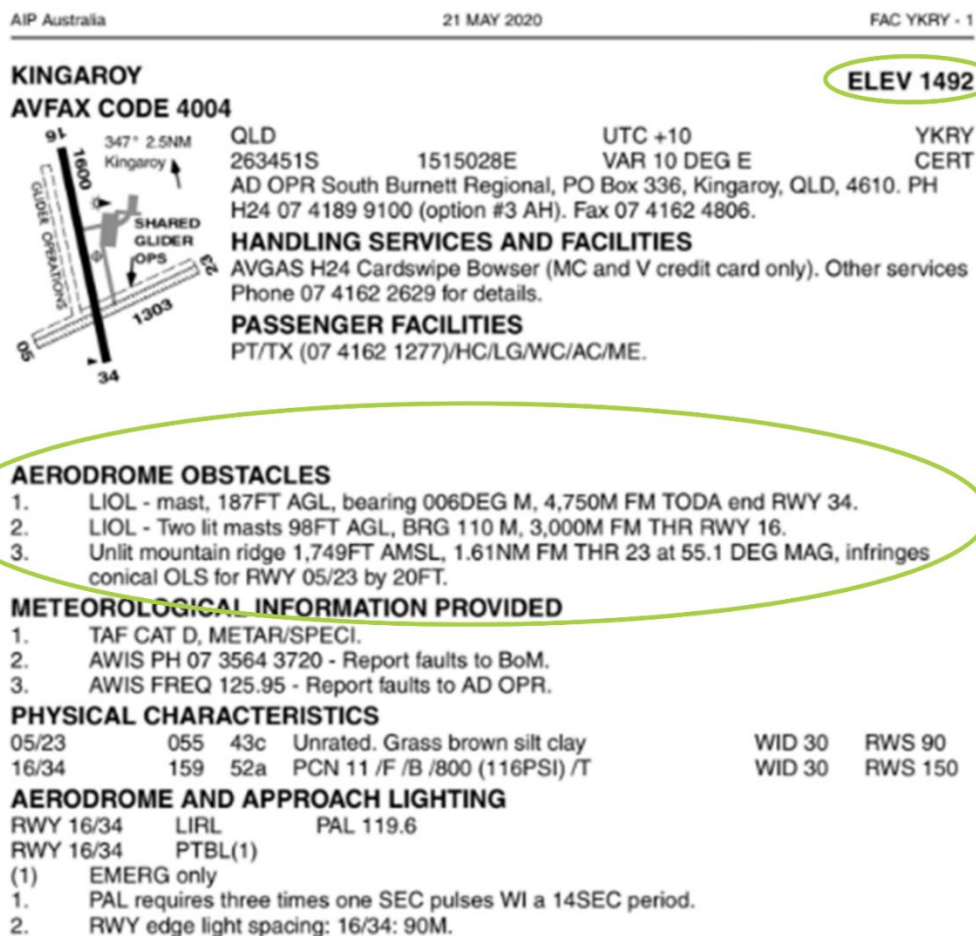

Figure 28 Kingaroy Aerodrome chart highlighting elevation

5.5 Using the GPS Terrain Features

Helicopters typically are unstable to fly and operate close to the ground. The terrain pages on the GPS (3) and the EFB (34) are constantly displayed in real time. Having this information immediately available to the pilot rather than requiring the pilot to interpret the information in the cockpit is a great safety benefit and allows for faster decision-making. The GPS and EFB should be readily available and utilized in bad weather situations.



Figure 29 GPS terrain page

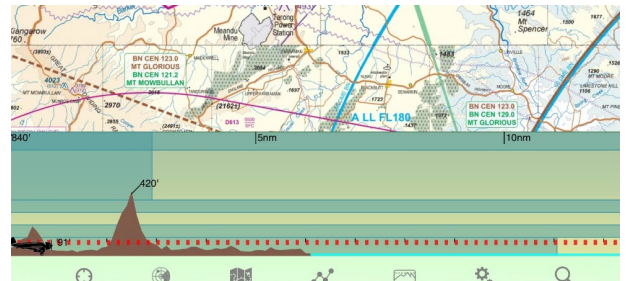

Figure 30 EFB terrain option

5.6 Using the Radar Altimeter

The radar altimeter (Figure 35 and Figure 36) is a particularly valuable tool when flying in flat light and at night when the ground cannot be seen. The pilot can set various altitude and proximity warnings that can be either transmitted to the pilot by an aural signal or interfaced with an electronic display showing the actual height AGL in real time.



Figure 31 Analog radar altimeter



Figure 32 Digital radar altimeter

It is important to note that a radar altimeter displays the current height AGL directly under the helicopter. It does not predict what the terrain is going to do moving forward nor is it able to warn of rising terrain. It is an invaluable tool if used correctly and the pilot is situationally aware of the topography.

5.7 Developing Pilot Experience

Through experience, pilots get to know what 500 ft AGL looks like from the cockpit (Figure 37). Although continued cruise at or below 500 ft is not encouraged, this is the domain of the working VFR helicopter pilot. Instinctively knowing what 500 ft AGL looks like from the cockpit is the first step in knowing when you are being forced to go below that height AGL in bad weather and should be a trigger for making an early decision for an alternative course of action.



Figure 33 Flying at 500 ft AGL

6 Visibility

Knowing how far into the distance you can see is an important first step in avoiding an IIMC event. We have already discussed how to determine a distance, so now we need to apply that information to visibility.

Flight visibility is defined as the average forward horizontal distance as viewed from the cockpit of an aircraft in flight at which an object can be seen and identified. By day, the object shall be unlit, and at night, the object may be lit.



Figure 34 Visibility by day



Figure 35 Visibility at night

Visibility may vary according to the direction, angle of view, and the height of the observer. Visibility is affected by the presence of fog, clouds, haze, dust, smoke, and precipitation and the effects of light (or darkness) (Figure 38 and Figure 39).

Note: Most information discussed in this section is for use under VFR during the day. Safely flying at night requires additional training and equipment installed in the aircraft. At night, if not flying over a lit urban environment, the pilot could be operating legally in complete compliance with the minimum VMC but, because it is dark, still be unable to maintain visual separation with the ground or have a discernible horizon required to maintain an attitude. Prior to any night flight, make sure to receive additional training and treat the flight as IFR, because those are the skills that will be required.

There are several methods to determine visibility prior to flight, which include

- getting a weather forecast and weather report prior to the flight,
- looking out the window and using your distance estimating skills,
- using the runway to estimate visibility,
- using distance traveled versus distance to go,
- listening to the local AWIS or ATIS of an airport in your local area, and
- asking other pilots who may have just returned from a flight.

6.1 Get a Weather Forecast and Weather Report Prior to the Flight

A weather forecast (Figure 40) projects forward to what may be expected in the future at a location (TAF) or over an area (ARFOR), whereas a report (METAR) will tell you what was actually happening at a particular time and location. Looking at them both can help tell a story and allow for a decision regarding a go, no-go, or go with a plan for an alternate course of action.

```
SUNSHINE COAST (YBSU)
(0.2 HRS OLD)
TAF AMD YBSU 280233Z 2802/2812
18012KT 5000 SHOWERS OF LIGHT RAIN FEW006 SCT020 BKN045
FM280500 16012KT 9999 SHOWERS OF LIGHT RAIN FEW010 SCT020 BKN050
TEMPO 2802/2806 3000 SHOWERS OF MODERATE RAIN SCT004 BKN008
INTER 2806/2812 4000 SHOWERS OF MODERATE RAIN BKN010
RMK
T 15 17 16 14 Q 1023 1022 1022 1023
```

Figure 40 Sample TAF

In today's electronic environment, we are also able to access weather radar, often overlaid on our route (Figure 41), or in other apps and websites. Most countries have some system allowing access to up-to-date weather information. It is simply up to you to prepare, interpret, and plan.

It is also important to note that you can get weather updates while in flight in real time (or near real time). These can be obtained from the EFB, by asking ATC, or even by asking other pilots in the area.

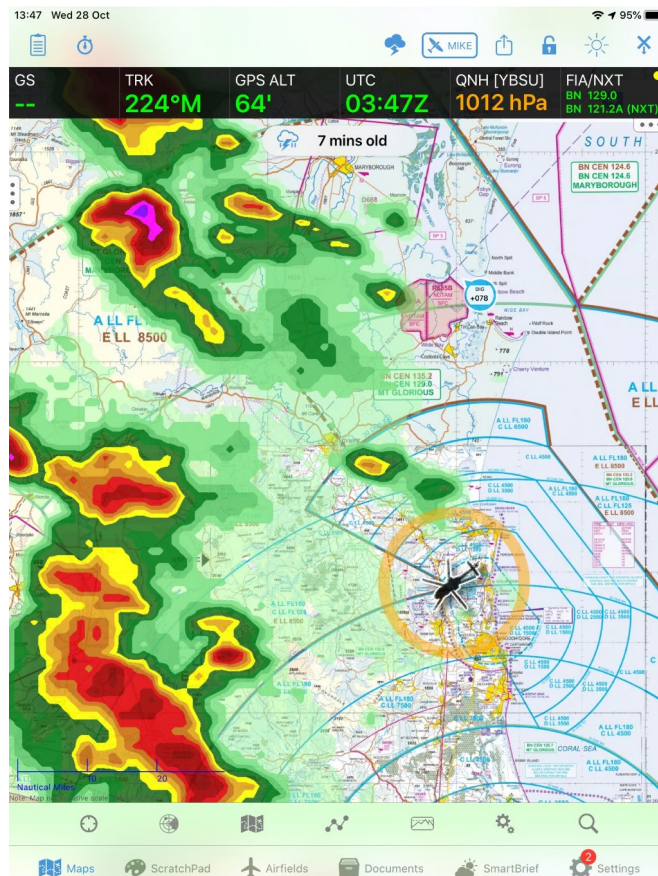

Figure 41 EFB showing weather radar

6.2 Look out the Window and Have a Look

Look out the window and have a look. How far can you see? If you are in an area you are familiar with, then getting to know how far away that water tower is, how far away a hill or mountain is, how far away a building is, can all help in relating that to a visibility distance. If it is an area you do not know, then look at the map and pick some features that should be visible at certain distances, then look out the window and identify them. Make a conscious effort to be aware of the visibility.

For example, consider the image first viewed during fine weather and with known obstacles noted. In the examples below (Figures 42 through 51), note how the weather is deteriorating, the visibility worsening, and the cloud base descending.



Figure 36 Viewing known features



Figure 37 Google Earth view of known features



Figure 38 Estimated visibility at 10km+ or 6+ SM with cloud base at 900 ft



Figure 39 Estimated visibility at 5000 m or 3 SM with cloud base at 1000 ft



Figure 40 Estimated visibility at 5000 m or 3 SM with cloud base at 750 ft



Figure 41 Estimated visibility at 3000 m or 2 SM with cloud base at 500 ft



Figure 42 Estimated visibility at 3000 m or 2 SM with cloud base at 750 ft



Figure 43 Estimated visibility at 800 m or 1/2 SM with cloud base at 400 ft



Figure 50 Estimated visibility at 500 m or 1/3 SM with cloud base at 250 ft



Figure 51 Estimated visibility at 400 m or 1/4 SM with cloud base at 100 ft

6.3 Use the Runway to Estimate Visibility

The runway is a great tool for estimating visibility prior to takeoff. A very common procedure used by fixed-wing IFR pilots to estimate the minimum required takeoff visibility is to look at the runway lights and the white markers on the runway, which are at very specific distances.

Example

If each set of lights is 60 m or 200 ft apart, how far down the runway can the pilot see in Figure 52? What is the visibility?



Figure 44 Foggy runway (Source: Timo.Kouwenhoven at www.skybrary.aero)

There are six sets of lights clearly visible, so there is approximately 360 m or 1200 ft of visibility. This is not a VFR day! This is not VMC; this is IMC, even though the pilot can still see out the window. Under IFR, this is enough to take off. Under VFR, the pilot should still be sitting in the office and not in the helicopter!

6.4 Distance Traveled versus Distance to Go

The idea behind the distance traveled versus distance to go technique is to use the GPS distance to go to the destination versus where the helicopter is now. Looking forward along the intended flight path, pick an obstacle or feature on the ground that represents the limit of your current visibility; in other words, one you cannot see past because the visibility has deteriorated. As the helicopter flies over the selected point, note the new distance to the destination. The difference between the two represents the current visibility.

This exercise helps pilots develop the instinctive feel for visibility and distance.

Example

The helicopter is currently 20 SM from the destination. Looking along the flight path you identify a peninsula on the coast (Figure 53). Once you fly over the peninsula, you note the new distance to the destination is 18 SM (Figure 54). This means the flight visibility is 2 SM.



Figure 45 Distance traveled versus distance to go: 20 NM



Figure 46 Distance traveled versus distance to go: 18 NM

The question you now must ask yourself is, “Is 2 SM enough visibility to continue on this flight?”

Should you actually be **making a decision for an alternative course of action now**, before it gets worse?

6.5 Listen to AWIS or ATIS of a Local Airport

Getting the weather at your local airport prior to departure or listening to airports close by while enroute can help fill in some blanks to your observations. These weather reports are updated whenever there is a change and can help you prepare for what is to come.

6.6 Ask Other Pilots Who May Have Just Returned from a Flight

This is something that is commonly done by experienced pilots but often avoided by very inexperienced pilots, as they do not want to come across as being new to the aviation game. Pilots are always keen to share, but often will do so only when asked, so never be afraid to ask someone who has just come from where you are going about the weather, whether via the radio, the phone, or in person.

6.7 Summary

When in flight, determining the visibility becomes more dynamic as the helicopter is moving at speed, so the visibility will not be static. The key is to look ahead a known (or estimated) distance to a feature, obstacle, or reference point and make a judgment on the current visibility. Is it remaining the same, is it improving, or is it getting worse? What are your comfort levels?

Set a personal limit, but no less than the prescribed minimums, so that a decision to reduce speed, descend, turn, divert, or land **is made early**.

Remember, if on a VFR flight:

If in doubt, there is no doubt.

You are going to land!



7 Cloud Base and Distance

Knowing the cloud base is important in order to avoid it and to give you a personal limit on when to turn around or land. This becomes more relevant when the terrain ahead is rising, even if the cloud base is remaining static.



Just as important is being able to determine how far away that cloud is, so you can make a decision to avoid it before entering it.

The biggest problem with clouds is that they are constantly changing; the base, the type, the thickness, the shapes, and the coverage are all part of the aviation gods' design to make you, the pilot, work hard.

Although being a fair-weather flyer is, on paper, a safer option, we often cannot choose when we need to go to work. This requires the pilot to be vigilant and constantly monitor the cloud. Prior preparation is always helpful, but to stay safe, nothing beats constant evaluation and reevaluation and **decision-making** during the flight.

Any forecast will always give cloud information, including the base and tops AMSL for en route or area forecasts and AGL for terminal (airport) forecasts. So, getting a weather forecast is a great advantage when planning a flight. Today, weather information has never been more available or accessible. No longer do we need to go to a briefing office and read through printed material. Today, we can access the weather instantly on a smart phone or tablet and receive immediate updates. Weather radar and Doppler are readily available in most urban areas. There are programs that will interpret these for you and explain them in plain English as well as overlay them on your planned route.

The downside is there is no briefing officer telling you the weather is no good for flying and you should be staying at home. The interpretation and decision are all yours to make!

However, there will be times when you may not have access to weather information or you are in an area where there is no local forecast, and you have to make the decisions yourself. Additionally, as helicopter pilots operating close to the ground, there will be microchanges in weather that simply cannot be forecast and that will require you to make your own determination and decisions while in flight.

The following are some nonelectronic tricks you can employ to evaluate the cloud:

- make observations prior to the flight
- calculate where the cloud base may be expected
- conduct in-flight visual checks
- ask another pilot
- determine the distance from the cloud.

7.1 Observation Prior to the Flight

Prior to the flight, look outside, and if there is an obstacle of a known height in your vicinity, determine if the cloud is above, at, or below that obstacle.

Make a determination on the base, the thickness, and the type of cloud. Can you see through it? Are there holes or is it solid?



Figure 47 Observation of clouds prior to flight

Example

Consider a 750 ft hill 1 mile away from your observation point (Figure 55). The cloud appears to be touching the top of the hill. That is a good indication the cloud base is about 750 ft. In this situation, and applying the 500 ft AGL rule, you only have 250 ft separation from the cloud if flying at sea level. If you are going to enter controlled airspace, can you, therefore, maintain VMC? Could you apply Special VFR? What **decision** will you make?

7.2 Calculation

If you know the OAT (outside air temperature) and the DP (dew point, where moisture in the atmosphere becomes visible as cloud) given in a METAR or AWIS report, then you can calculate where the cloud base may be expected if there is sufficient moisture in the air (humidity).

Example

METAR YBBN 252030Z CAVOK 08/06 Q1020

In the above METAR, the OAT is 8 degrees on the ground and the DP is 6 degrees.

At the standard lapse rate of 2 degrees per thousand feet, a cloud could be expected to form at approximately 1000 ft above the ground if there is sufficient moisture in the air (Figure 56).

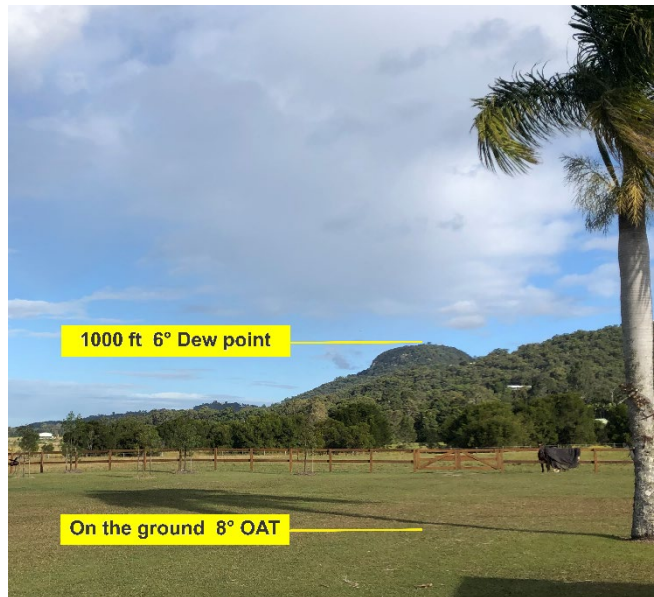

Figure 48 Dew point example

Temperature and dew point are also good indicators of visibility when considering moisture in the air. If the temperature and dew point are far apart, visibility is often good. If the temperature and dew point are close, visibility is deteriorating.

For example:

With a temperature of 6°C and a dew point of 6°C (06/06), you are in fog or cloud. The air is saturated.

With a temperature of 25°C and a dew point of 5°C (25/05), there is not much moisture in the air and visibility is good.

With a temperature of 25°C and a dew point of 22°C (25/22), the air is very moist and visibility could be declining.

7.3 In-Flight Visual Checks

When cruising at a particular altitude, look out the side window and note whether the cloud base appears higher than, the same height as, or lower than you. Then look back at your altimeter and make your own determination on cloud base. This also allows you to give yourself a personal limit for the flight based on a known cloud base.



Be cautious when looking directly out the front for cloud height information because this can often be deceiving. It is very difficult to estimate actual distance and closure rate from a low-contrast cloud.

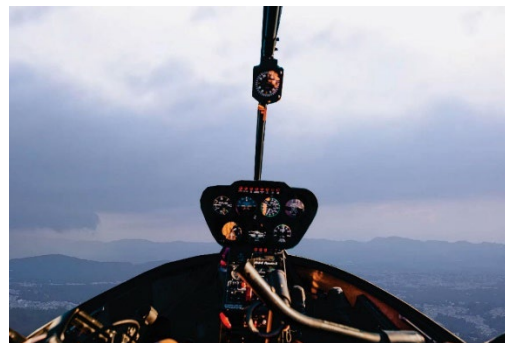

7.4 Asking Another Pilot

Ask another pilot, particularly an IFR pilot who may have just climbed up to or descended through the cloud base. Other pilots are often happy to help, as are ATC, if they are available.



7.5 Distance from the Cloud

Distance from the cloud is harder to determine, as you need some depth perception and a reference point. In a moving aircraft, these two things are difficult to achieve; however, there are some tricks that a pilot can employ.

If there are shadows on the ground, then look at an area on the ground where the cloud shadow is cast. Using your newly acquired distance measuring skills, estimate the distance.

Example

In Figure 57, the cloud can be seen in the distance. Looking directly down, you can see the shadow line. There is a small patch of isolated cloud directly on the nose at approximately $\frac{1}{2}$ a mile and a more solid line of cloud approximately 1 SM away. It looks to be almost at the same level as the helicopter, although a look out the side window will make that more evident. At the current speed of 90 kt, the helicopter will reach the first patch of cloud in 20 seconds and the larger line of cloud in 40 seconds.



Figure 49 Calculating distance to cloud

What decision and actions should the pilot be taking now to avoid the cloud?

If there are no shadows, then this technique is obviously not going to work, but the same principles of time and distance can still be applied. When looking outside and seeing a cloud, estimate the distance you think the cloud is from the helicopter and translate that into a time. This reflects the time you have available to take some corrective action.

Example

The pilot sees a line of cloud along the flight path with the base lower than the current cruising altitude. Estimating the cloud to be 3 SM away and flying at 120 kt, the estimated time to the cloud is 90 seconds. Just making the calculation has probably taken 15 seconds, so now there are only 75 seconds to make a decision and take corrective action to avoid the cloud, which may be as simple as descending to a lower level.



Note: Understanding the application of an enroute decision trigger (EDT) discussed in the VAI Training Working Group white paper, VAI Decision-Making and IIMC, the pilot should actually consider an alternative course of action before reaching the reduced weather.

8 Make a Decision

Now that you have gained some knowledge and developed some skill, you have to repeat it to develop a behavior. You have also collected some information on the flight, so it is time to put it all together and make a decision prior to commencing the flight, and then keep making decisions based on what transpires throughout the journey.

As helicopter pilots, we fly low to the ground, our environment is constantly changing, and our flight path often deviates from the original plan developed prior to the flight. Because of this, we must develop the skill of constantly reevaluating the situation and making decisions to maintain safety throughout the flight.

This is very different from the airline pilot, who has a completely programmed flight and, in essence, is conducting the same operation to the same procedures every time. Airliners fly in a predictable, controlled environment. Helicopter pilots do not.

Decisions when flying are based on the following criteria:

- What are the rules? (VFR)
- What is the forecast weather?
- What type of operation am I conducting? (The rules may vary for different operations.)
 - Private
 - Commercial
 - Passenger carrying
- What am I qualified and trained for?
- What am I current in?
- What are the company policies, procedures, and limitations?
- What are my personal limitations?
- What is the aircraft certified for?

Enroute Decision Triggers

The helicopter industry is now promoting the enroute decision trigger (EDT), also referred to as the enroute decision point (EDP).

This means that the company, operator, or pilot has set some minimums with regard to speed, height, cloud base, and visibility that are particular to the aircraft, the operation, and/or the pilot. These are determined prior to the commencement of the flight.

The crew now have a set of parameters that **trigger a decision** if any one of the triggers looks like it is being met. There is no longer any other decision to make except activating the alternative course of action which, for the VFR pilot, will include turning to clear weather or landing. The IFR pilot in an IFR aircraft may have other options, such as changing category to IFR and continuing IMC.

EDT/EDP usage, aeronautical decision-making, and IIMC management are covered in the VAI Training Working Group white paper, *VAI Decision-Making and IIMC*.